

5-axis CNC machining centers,
passage in Z from 500 mm



CMS is part of SCM Group, a technological world leader in processing a wide range of materials: wood, plastic, glass, stone, metal, and composites. The Group companies, operating throughout the world, are reliable partners of leading manufacturing industries in various market sectors, including the furniture, construction, automotive, aerospace, ship-building, and plastic processing industries. SCM Group coordinates, supports, and develops a system of industrial excellence in three large, highly specialized production centers employing more than 4,000 workers and operating in five continents. SCM Group: the most advanced skills and know-how in the fields of industrial machinery and components.

CMS SpA manufactures machinery and systems for the machining of composite materials, carbon fiber, aluminum, light alloys, plastic, glass, stone, and metals. It was established in 1969 by Mr Pietro Aceti with a vision of offering customized and state-of-the-art solutions, based on the in-depth understanding of the customer's production needs. Significant technological innovations, originating from substantial investments in research and development and take-overs of premium companies, have enabled constant growth in the various sectors of reference.



CMS Plastic Technology produces numerically-controlled machining centres and thermoforming machines for the working of plastic materials, offering technologically advanced solutions. The brand originates from the winning synergy between the technical-industrial expertise in thermoforming of the historical company Villa, established in 1973, and CMS' historical know-how in milling. Thanks to constant investments in research and innovation, CMS Plastic Technology is recognized as unique partner for the whole process: from thermoforming to trimming to the realization of models and moulds, ensuring maximum productivity. CMS Plastic Technology is in the forefront of manifold sectors, such as: automotive, aerospace, earth-moving machinery, caravans, buses, railway industry and production of bathtubs.

ares

APPLICATIONS	4-5
ARES / ARES APC / ARES TR TECHNOLOGICAL BENEFITS	6-9
WORKING UNITS	10
TOOL CHANGER MAGAZINES	11
ACCESSORIES	12-15
SPECIAL SOLUTIONS	16-17
DIMENSIONS & TECHNICAL DATA	18-21
CMS CONNECT	22
CMS ACTIVE	23
SERVICE	24-25
THE RANGE	26-27



APPLICATIONS



caravan | furniture | marine industry | automotive



medical | earth moving machines | mass transport | aerospace



Unparalleled.

New.

Innovative.

Quality.

Ultra.

Effective solutions.

The **UNIQUE cnc machines.**

5-axis CNC machining centers, passage in Z from 500 mm

ARES

TECHNOLOGICAL BENEFITS

Integrated machining center for vertical milling, ideal for **plastic processing**. The advanced design of its structures and the result of CMS's continuous investments in R&D with the sophisticated technological solutions adopted, provide **rigidity** and **precision** over time, and **exceptional movement dynamics**. These features guarantee **quality finishing levels, unparalleled accuracy and a high productivity level**.

- **Very large working areas** for maximum productivity freedom, wide range of electrospindles, fully designed and manufactured within the SCM Group.
- **Wide configurability of the working areas** (single zone or pendular cycle).
- **Precision** suited to the most demanding applications (**aerospace, motor sports, etc.**)
- **CMS Adaptive Technology**, function integrated into the control that allows the operator to achieve **maximum removal parameters** of material on a specific surface by simply calling up the relevant mapping. CMS Adaptive Technology **significantly reduces cycle times** on complex surfaces without compromising the finishing quality and precision.



KEY BUYER BENEFITS

- + **SPACE EFFICIENCY:** excellent workable cubic space/encumbrance ratio.
- + **HIGH PRODUCTIVITY** with zero downtime.
- + **RELIABILITY!** More than 1,300 machines installed worldwide.



PRODUCING MORE IS BETTER: TODAY AND TOMORROW

The advanced design of the structure, the work of CMS' research center and the technical solutions adopted, guarantee **rigidity and precision over time** to the point where top **quality finishing and accuracy of the pieces** become a fixed feature of your production over the years. The ares machine accuracy is the best-in-class in its industry category: **+23% machining precision and accuracy**.



NO LIMITS CONFIGURABILITY

Ares has **large working areas** to offer **maximum freedom** and **new production opportunities**. The extensive configurability of the working areas with the option of pendular working, as well as the possible versions with extractable (APC) and rotating (TR) tables, make the ares machine the solution that can genuinely change every company.



CLEANING AND SAFETY: EFFICIENCY FOR SUCCESS

Designed for maximum efficiency in dealing with dust, it is fitted with the most advanced containment and suction systems to guarantee a **clean, safe work environment for operators as well as being fully reliable**, essential requirements for achieving the **highest levels of production efficiency**.

ARES APC

TECHNOLOGICAL BENEFITS

All the capabilities of the Ares machine with the advantage of extractable working tables APC (Automatic Pallet Change) allows for loading and unloading outside the working space giving easy access to the tables and ensure operator is protected from dust and noise. The APC system can work in 2 different ways:

- **Alternate cycle tables:** the tables work independently or alternating;
- **Coupled tables:** the two tables are coupled to create a large working area.



ARES TR

TECHNOLOGICAL BENEFITS

Ares 3618 and **Ares 4818** are also available with rotating working tables (TR).

- **Reduced overall dimensions** for the same working areas
- The machine can **easily be fixed** in the pre-existing working environment
- **Reduced time for loading / unloading.**

The rotating table (TR) is managed by a CN axis to ensure speed, accuracy, position repeatability and reliability.



ARES

WORKING UNITS

PX5 WORKING UNIT



CX5 WORKING UNIT



HX5 WORKING UNIT



THE POWER OF INNOVATION



All the **electrospindles** are fully designed and manufactured within the group and are the result of 30 years of experience and continuous innovation. The wide range allows our customers to always have the electrospindle with the ideal torque, power, and RPM features for their machining, **maximizing the machine's productivity.** In addition to the milling units, it is possible to add an ultrasonic cutting unit, combining the two technologies for an **exceptional synergy in the processing of core materials.**

ARES

TOOL CHANGER MAGAZINES



8-place tool changing magazine



Pick-up tool magazine

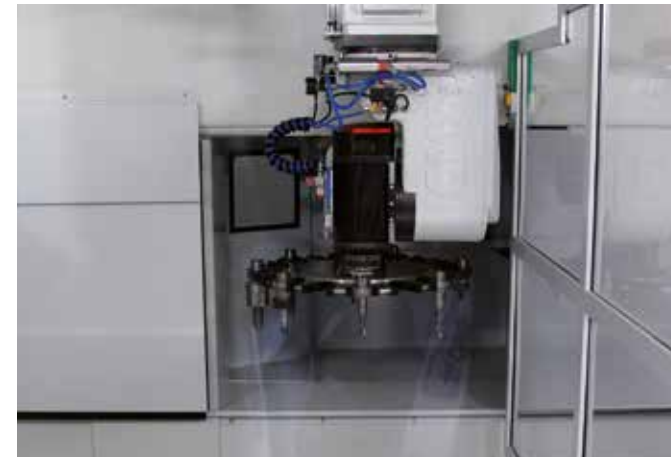

Tool-disk magazine



Tool-chain magazine with exchange handgrip

ARES

ACCESSORIES



Bellow-type roof for fumes, dust and chips control



Soundproof full enclosure for dust control and for machine's lighting



Dust extraction vents



Suction tanks



Chips management with integrated conveyor



4-positions telescopic dust suction hood



Laser device for measuring tool length and diameter



Device for rotary axis control and alignment

ARES

ACCESSORIES



Ultrasonic



MQL SYSTEM
Maximum efficiency with minimum lubricant consumption. The MQL systems, associated with electrospindles with air/oil flow inside the tool, guarantee perfect lubrication even under critical situations



Cold air gun



Electronic touch probe

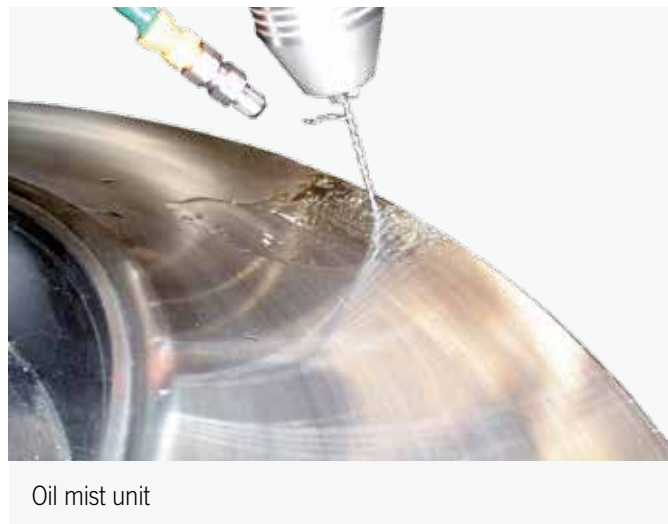

Oil mist unit

WORKING TABLES



Standard



Aluminum vacuum table

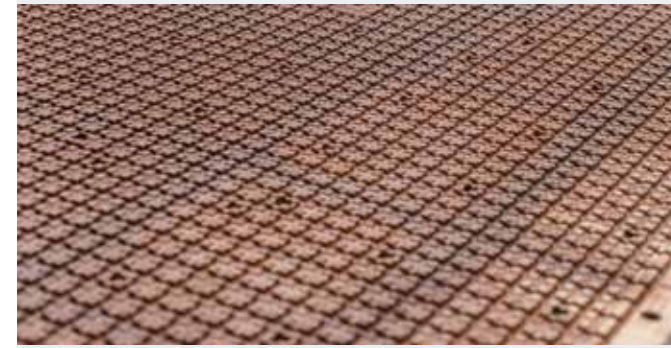

Multilayer phenolic vacuum table



Aluminum vacuum table with T slots



Vacuum / Air connections



Vacuum connections



Reference stop

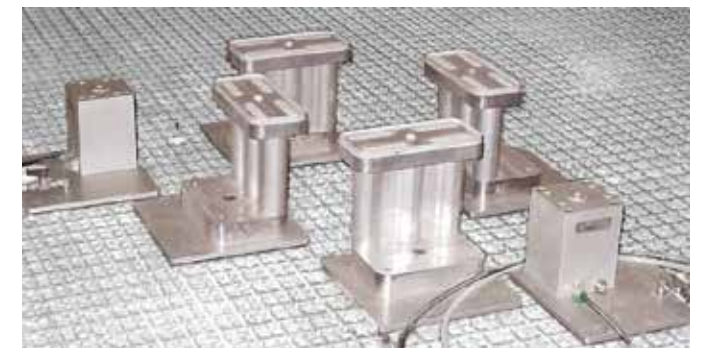

Pods and reference stops



NC controlled stock and tailstock group

ARES

SPECIAL SOLUTIONS



Ares with extractable working tables APC (Automatic Pallet Change) and double bridge



Ares with single extractable working table 1APC (Automatic Pallet Change)



Ares with rotating table and double bridge

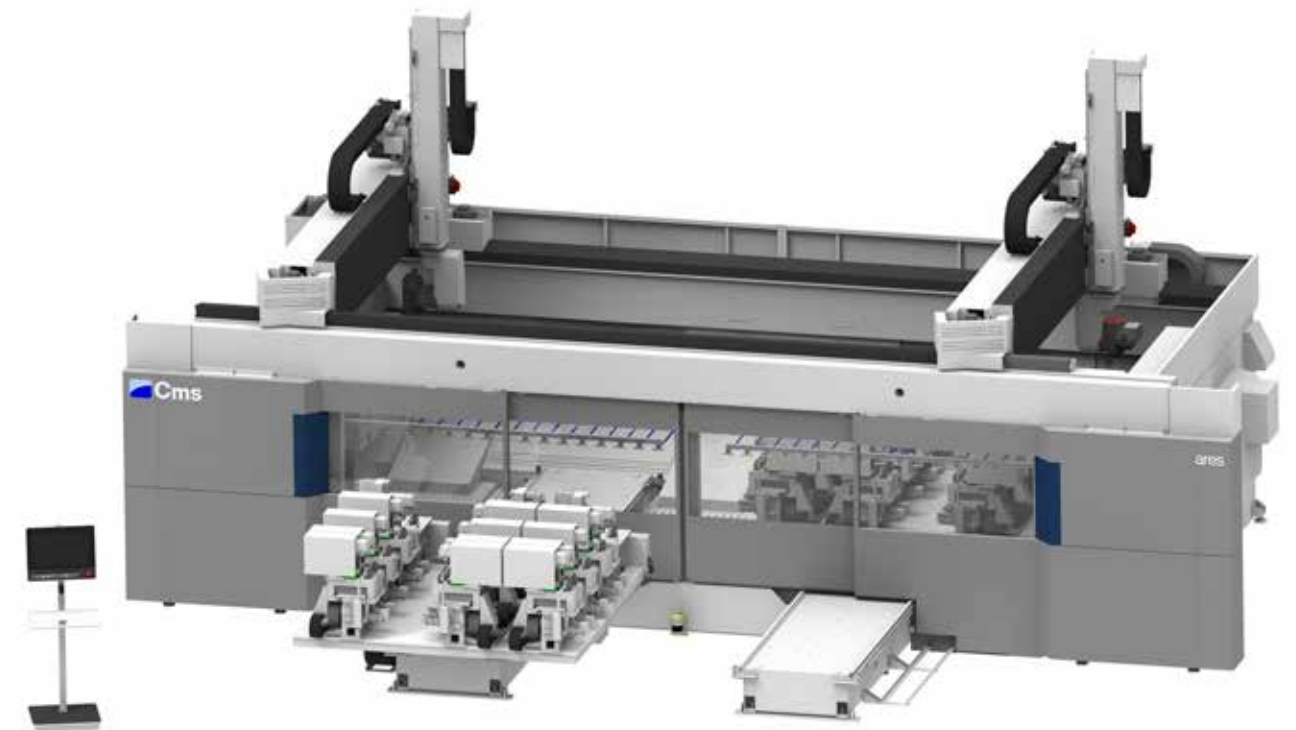

Ares with extractable working tables APC (Automatic Pallet Change) with double bridge and 5-axis unit with 3 spindles

ARES

DIMENSIONS AND TECHNICAL DATA

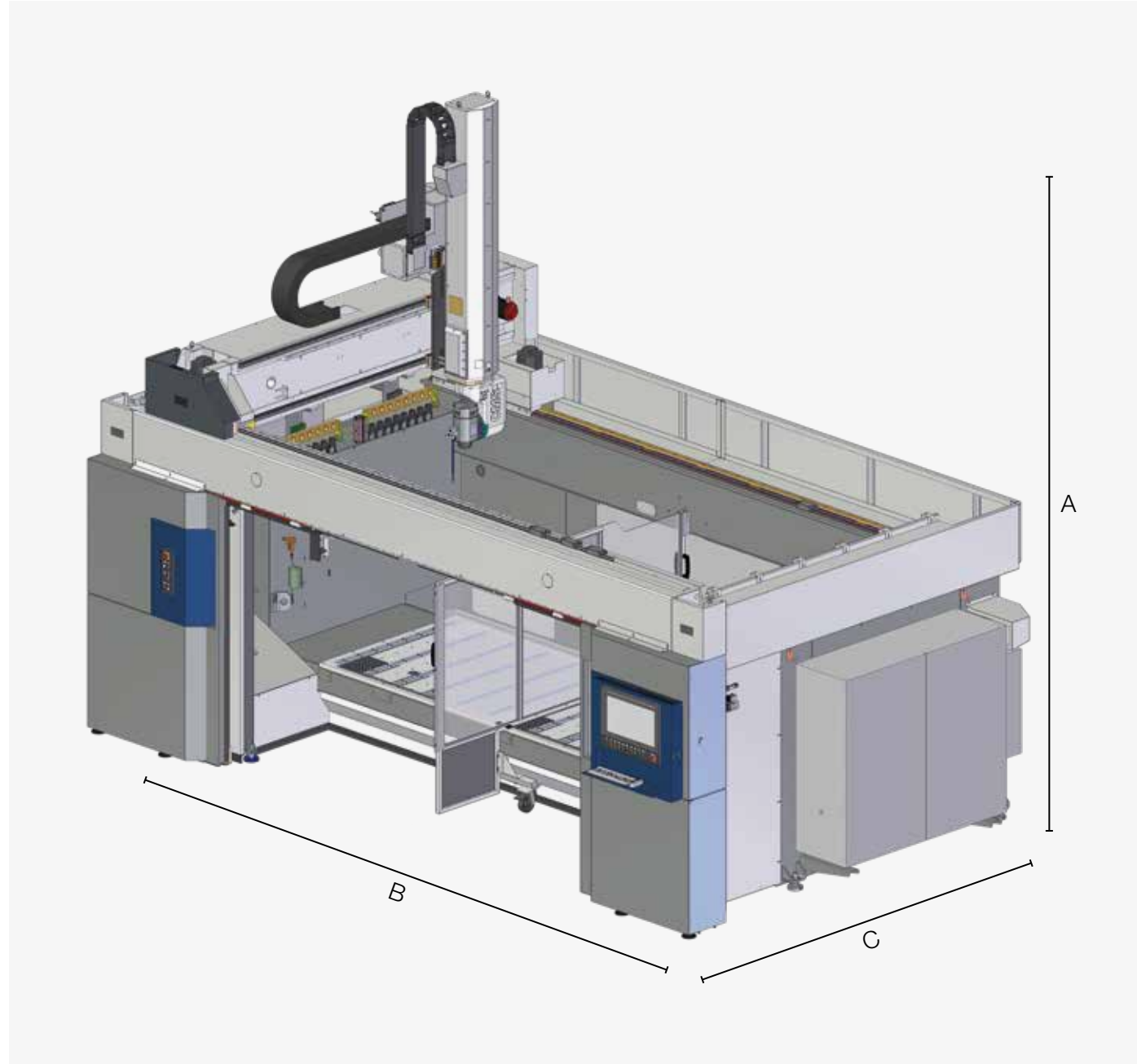

ARES: STROKES AND SPEEDS

MODEL	AXIS STROKES					RAPIDS			
	(mm)			(°)		(m/min)		(°/min)	
	X	Y	Z	B	C	X/Y	Z	B	C
3618	3600	1800	1200	±120	±270	80	70	9000	
4818	4800								
6018	6000								
3626	3600	2600	1200	±120	±270	80	70	9000	
4826	4800								
6026	6000								

ARES: ENCUMBRANCE (mm)

A	Z AXIS STROKE		
		1200	
	4450 / 4600*		
B	X AXIS STROKE		
	3600	4800	6000
	6400	7810	9610
C	Y AXIS STROKE		
	1800	2600	
	3675	4525	

* With roof.

ARES: WORKING PLANES

MODEL	DIMENSIONS (mm)
ARES 3618	3640x1360
ARES 4818	4870x1360
ARES 6018	6070x1360
ARES 3626	3640x2360
ARES 4826	4870x2360
ARES 6026	6070x2360

ARES WORKING UNITS AND ELECTROSPINDLES

	CX5 - 8_40	CX5 - 8,5_24	CX5 - 10_24	PX5/HX5 - 12_24	PX5/HX5 - 15_24	PX5/HX5 - 20_24 (sincronous)
B,C STROKES	B= ±110°, C= ±360°			B= ±120°, C= ±270°		
RAPID B,C	10800 °/min			9000°/min		
NOMINAL POWER (S1)	8 kW	8,5 kW	10 kW	12 kW	15 kW	20 kW
MAX POWER	9 kW	10 kW	12 kW	14 kW	17 kW	22,3 kW
MAX RPM	40.000 rpm	24.000 rpm	24.000 rpm	24.000 rpm	24.000 rpm	24.000 rpm
MAX TORQUE	6 Nm	8 Nm	9,5 Nm	11,1 Nm	13,8 Nm	20,1 Nm
TOOL CHANGER	AUTOMATIC					
TOOL HOLDER	HSK 32 E	HSK 63 F	HSK 63 F	HSK 63 F	HSK 63 F	HSK 63 A
COOLING	LIQUID					

ARES: TOOL CHANGER MAGAZINES

	Standard for cX5	Standard for PX5	OPTIONS				
NO. STATIONS	6 on board	8 on board	Additional 8 on board (not compatible with central safety barrier)	12 on board	20 carousel	8 pick up	48 chain type with exchange lever
HOLDER INTERAXES (MM)	100	80	80	80	93	80	104
Ø MAX WITHOUT LIMITATION (MM)	90	70	70	70	85	70	100
Ø MAX WITH LIMITATION (MM)	250	400	400	400	200	400	250
MAX TOOL LENGHT (MM) *	265	265	165	265	465	465	435
MAX WEIGHT SINGLE TOOL	3 kg	3 kg	3 kg	3 kg	6 kg	5 kg	6 kg

* Values from the spindle nose.

PRECISIONS AND REPEATABILITY

LINEAR AXES*	REFERENCE STROKE	A	R
X/Y	2000 mm	0.022 mm	0.014 mm
Z	1200 mm	0.018 mm	0.012 mm
B	± 120°	26 arcsec	
C	360°	16 arcsec	

* Precision with linear scales and direct encoders on PX5 accuracy (A) and repeatability (R) on the basis of the ISO 230-2 regulations.

ARES APC

DIMENSIONS AND TECHNICAL DATA

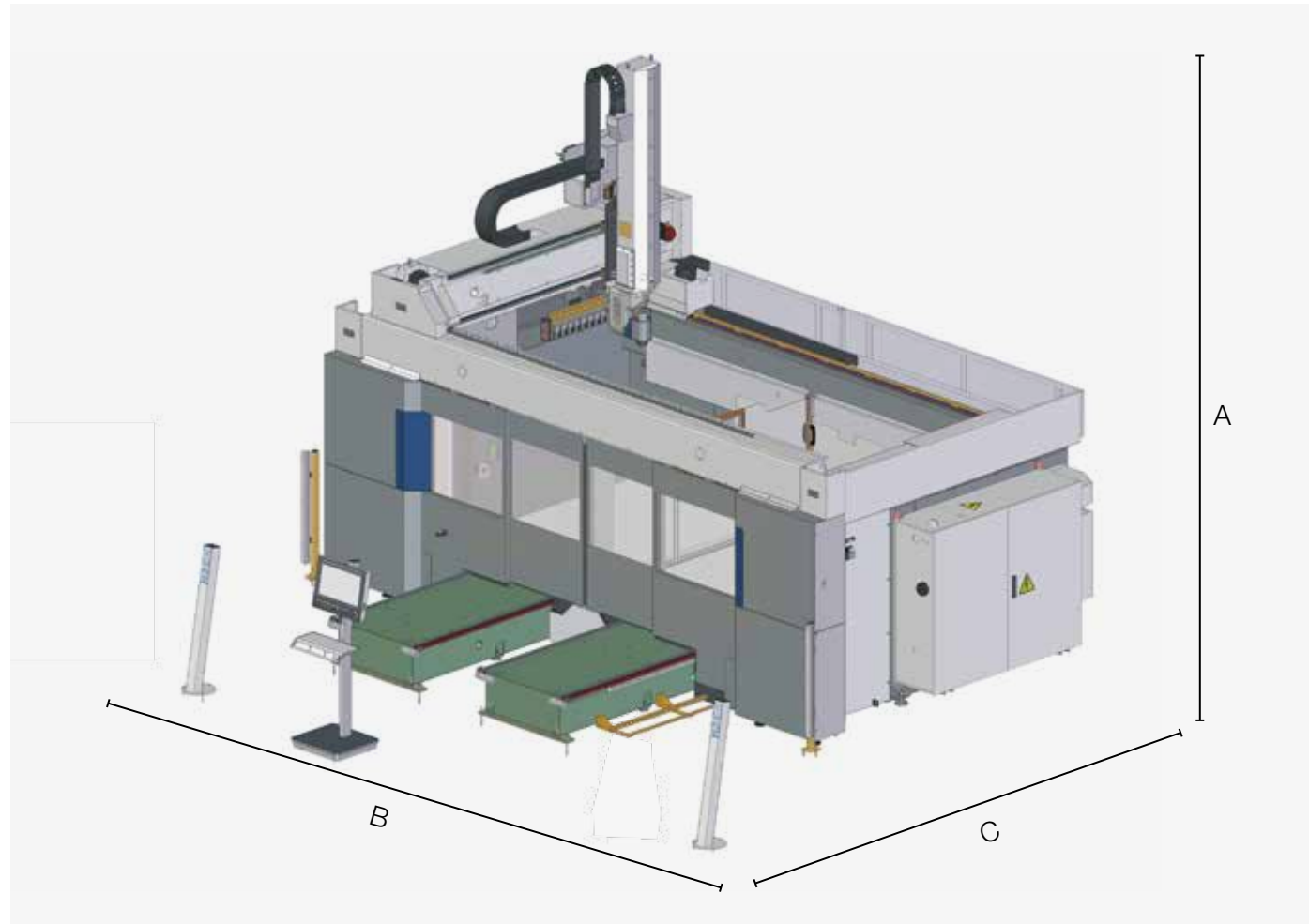

ARES APC: STROKES AND SPEEDS

MODEL	AXIS STROKES					RAPIDS			
	(mm)			(°)		(m/min)		(°/min)	
	X	Y	Z	B	C	X/Y	Z	B	C
3618	3600	1800	1200	±120	±270	80	70	9000	
4818	4800								
6018	6000								
3626	3600	2600	1200	±120	±270	80	70	9000	
4826	4800								
6026	6000								

ARES APC: ENCUMBRANCE (mm)

A	Z AXIS STROKE		
		1200	4450 / 4600*
B	X AXIS STROKE		
	3600	4800	6000
	6400	7810	9610
C	Y AXIS STROKE		
	1800	2600	6450
	6450	7670	

ARES APC: WORKING TABLES

MODEL	DIMENSIONS (mm)
ARES 3618	(1560x1360) x 2
ARES 4818	(2160x1360) x 2
ARES 6018	(2460x1360) x 2
ARES 3626	(1560x2020) x 2
ARES 4826	(2160x2020) x 2
ARES 6026	(2460x2020) x 2

* with roof.

ARES TR

DIMENSIONS AND TECHNICAL DATA

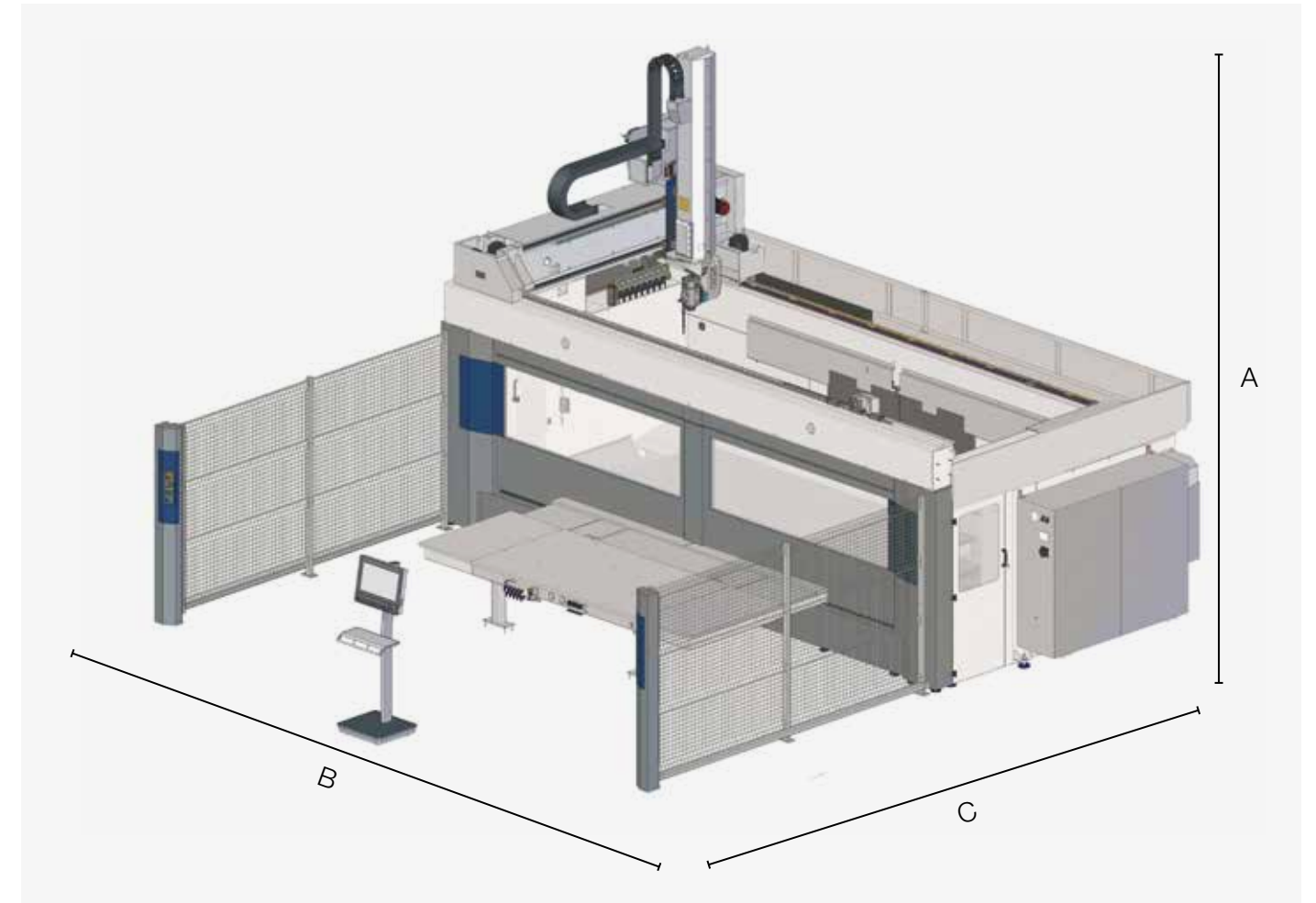

ARES TR: STROKES AND SPEEDS

MODEL	AXIS STROKES					RAPIDS			
	(mm)			(°)		(m/min)		(°/min)	
	X	Y	Z	B	C	X/Y	Z	B	C
ARES 3618 TR	3600	1800	1200	±110	±270	80	70	9000	
ARES 4818 TR	4800	1800	1200	±110	±270	80	70	9000	

ARES TR: ENCUMBRANCE (mm)

A	Z AXIS STROKE		
		1200	4450 / 4600*
B	X AXIS STROKE		
	3600	4800	6400
	6400	7810	
C	Y AXIS STROKE		
	1800	2600	6660
	6660		

* with roof.

ARES TR: WORKING TABLES

MODEL	DIMENSIONS (mm)
ARES 3618 TR	(2290x1195) x 2
ARES 4818 TR	(3540x1140) x 2

CMS connect the IoT platform perfectly integrated with the latest-generation CMS machines

CMS Connect is able to offer customised micro services through the use of IoT Apps that support the daily activities of industry operators - improving the availability and use of machines or systems. The platform displays, analyses and monitors all data from connected machines. The data collected by the machines in real time become useful information increase machine productivity, reduce operating and maintenance costs and cut energy costs.



CMS active a revolutionary interaction with your CMS machine

Cms active is our new interface. The same operator can easily control different machines as the “CMS Active interfaces maintain the same look&feel, icons and iteration approach.



APPLICATIONS

SMART MACHINE: Section designed for the continuous monitoring of machine operation, with information on:

Status: machine status overviews. The representations provided allow machine availability to be checked - to identify possible bottlenecks in the production flow;

Monitoring: instantaneous, live display of the operation of the machine and its components, of currently running programs and potentiometers;

Production: list of machine programs run within a given timeframe with best time and average running time;

Alarms: active and historical warnings.

SMART MAINTENANCE

This section provides a first approach to predictive maintenance by sending notifications when machine components indicate a potentially critical state associated with reaching a certain threshold. In this way, it is possible to take action and schedule maintenance services, without any down-time.

SMART MANAGEMENT

Section designed for KPI presentation for all the machines connected to the platform. The indicators provided assess of the availability, productivity and. The indicators provided assess of the availability,

productivity and efficiency of the machine and the quality of the product.

MAXIMISED SECURITY

CMS Connect uses the standard OPC-UA communication protocol, which guarantees the encryption of data at Edge interface level. CMS Connect's Cloud and DataLake levels meet all state-of-the-art cyber-security requirements. Customer data are encrypted and authenticated to ensure total protection of sensitive information.

ADVANTAGES

- ✓ Optimisation of production performance
- ✓ Diagnostics to support components warranty optimisation
- ✓ Productivity increase and downtime reduction
- ✓ Improvement of quality control
- ✓ Maintenance costs down

EASE OF USE

The new interface has been especially developed and optimized to be immediately used via touch screen. Graphics and icons have been redesigned for user-friendly and comfortable navigation.

ADVANCED ORGANIZATION OF PRODUCTION

Cms Active enables configuring different users with different roles and responsibilities according to the operation mode of the machining centre (e.g.: operator, maintenance man, administrator, ...).

It is also possible to define the work shifts on the machining centre and then survey activities, productivity and events that have occurred in each shift.

ABSOLUTE QUALITY OF THE FINISHED WORKPIECE







With CMS aActive the quality of the finished workpiece is no longer jeopardized by worn-out tools. The new Tool Life Determination system of CMS Active sends warning messages when the tool life is running out and recommends its replacement at the most appropriate time.

TOOL SET-UP? NO PROBLEM!

CMS Active guides the operator during the tool magazine set-up phase, also allowing for the programs to be run.



SERVICE OUR TECHICIANS BY YOUR SIDE ALL OVER THE WORLD

-  Training
-  Installation
-  Remote Customer Care (RCC)
-  On-site assistance
-  Maintenance
-  Changes & Retrofitting
-  Spare Parts

A GLOBAL PRESENCE FOR BEST-IN-CLASS SERVICE

- 36,000 different codes to serve machinery of all ages;
- 1 central warehouse at the headquarters in Zogno and 6 bases around the world fully integrated at IT level and controlled by a shipping optimisation software to reduce waiting times;
- 98% of orders available in stock;
- spare parts guaranteed thanks to a scrupulous control process and validation via our internal quality laboratory;
- availability to draw up recommended spare parts lists based on client needs, to reduce down time to a minimum;

THE CMS PLASTIC TECHNOLOGY

RANGE TO PROCESS PLASTIC MATERIAL

3/5 AXES MACHINING CENTERS (PASSAGE IN Z UP TO 500 MM)



TRACER



TIME



EVOTECH

5 AXES MACHINING CENTERS (PASSAGE IN Z FROM 500 MM)



ATHENA



ANTARES



ARES



GENESI

BEAM SAWS



HELIX

SAWS



T-MAXI

THERMOFORMING MACHINES



EIDOS



EIDOS SE



BR5 SPECIAL SPA



MASTERFORM

WATERJET CUTTING SYSTEM



TECNOCUT PROLINE



TECNOCUT SMARTLINE



C.M.S. SPA
via A. Locatelli, 123 - 24019 Zogno (BG) - IT
Tel. +39 0345 64111
info@cms.it
cms.it

a company of **scm**group